

Method of test for

Ignitability (surface flash) of pile fabrics and assemblies having pile on the surface

UDC [677.014.27:543.873]:677-488.3

Cooperating organizations

The Fibres, Yarns, Fabrics and Production Standards Committee under whose direction this British Standard was prepared, consists of representatives from the following:

Association of Jute Spinners and Manufacturers
 British Nonwoven Manufacturers' Association
 British Railways Board
 British Textile Employers' Association*
 Central Council of the Irish Linen Industry
 Consumer Standards Advisory Committee of BSI*
 Department of Industry (Chemicals and Textiles)
 Institute of Purchasing and Supply
 International Wool Secretariat*
 Knitting Industries' Federation Ltd.
 Man-made Fibres Producers' Committee*
 Manchester Chamber of Commerce and Industry
 Ministry of Defence*
 Narrow Fabrics Federation
 Warp Knitters' Association Ltd.

The organizations marked with an asterisk in the above list, together with the following, were directly represented on the Technical Committee entrusted with the preparation of this British Standard:

Association of Heavy Textile Proofers of Great Britain
 British Burn Association
 British Clothing Industry Association
 British Lace Federation
 British Plastics Federation
 British Resin Manufacturers' Association
 British Textile Rental Association
 British Throwsters' Association
 Chemical Industries Association
 Chief and Assistant Chief Fire Officers Association
 Continental Quilt Association
 Department of Health and Social Security
 Department of Industry (Laboratory of the Government Chemist)
 Department of the Environment (PSA)
 Department of Trade
 Department of Trade (Consumer Safety Unit)
 Industrial Safety (Protective Equipment) Manufacturers' Association
 Design Council
 Manchester Testing House
 Royal Society for the Prevention of Accidents
 Soap and Detergent Industry Association
 Society of Dyers and Colourists
 Society of Motor Manufacturers and Traders Limited
 Textile Institute
 Textile Research Council

Amendments issued since publication

Amd. No.	Date of issue	Comments

This British Standard, having been prepared under the direction of the Fibres, Yarns, Fabrics and Production Standards Committee, was published under the authority of the Board of BSI and comes into effect on 28 February 1983

© BSI 10-1999

First published February 1970
 First revision February 1983

The following BSI references relate to the work on this standard:

Committee reference FBM/19
 Draft for comment 81/37067 DC

ISBN 0 580 13208 0

Contents

	Page
Cooperating organizations	Inside front cover
Foreword	ii
<hr/>	
1 Scope	1
2 Definition	1
3 Principle	1
4 Apparatus	1
5 Conditioning and testing atmospheres	1
6 Health and safety of operators	1
7 Test specimens	3
8 Procedure	3
9 Assessment	4
10 Test report	4
<hr/>	
Figure 1 — Apparatus with specimen mounted	2
Figure 2 — Burner	3
<hr/>	
Publications referred to	Inside back cover
<hr/>	

Foreword

This British Standard has been prepared under the direction of the Fibres, Yarns, Fabrics and Production Standards Committee and forms a revision of BS 4569:1970 which is now withdrawn.

When the standard was originally prepared, a number of incidents had occurred in which fabrics having a long pile, usually in imitation of a fur, had become ignited and exhibited what is known as "surface flash". This phenomenon results from the high flammability of the pile fibres and is accompanied by a very rapid spread of flame across the surface of the fabric, usually without significant damage to the ground cloth.

A method of testing pile fabrics for susceptibility to this behaviour was evolved by the Flammability Working Party of the Textile Institute¹⁾ and the method of test described herein is similar to that proposed but with the following differences.

- a) A mechanical device for holding and moving the gas burner has been included instead of the manual procedure described earlier.
- b) A substantially smaller test specimen is specified.
- c) The sides of the specimen are not stapled back and the specimen is mounted on a non-combustible back-plate.
- d) Only one traverse of the specimen is made instead of four.
- e) Use of the wash bottle has been deleted.

This method of test has been applied to a wide variety of pile fabrics and has been found to give consistent results in the detection of liability to surface flash.²⁾

The method deals solely with surface flash and is inappropriate for determination of the total flammability of pile fabrics; this latter should be related to BS 5438 and the various performance standards which have been developed for different end uses.

This revision has been prepared to take account of a number of technical changes, the most important of which is the introduction of a procedure for testing specimens made up from two or more small pieces of the fabric under test when the sample is not sufficiently large to provide complete specimens of the required size, e.g. when a fabric taken from a toy is being tested.

A British Standard does not purport to include all the necessary provisions of a contract. Users of British Standards are responsible for their correct application.

Compliance with a British Standard does not of itself confer immunity from legal obligations.

Summary of pages

This document comprises a front cover, an inside front cover, pages i and ii, pages 1 to 4, an inside back cover and a back cover.

This standard has been updated (see copyright date) and may have had amendments incorporated. This will be indicated in the amendment table on the inside front cover.

¹⁾ See J.Text. Inst., 1968, 59, 47.

²⁾ See Text. Inst. and Industr., 1969, 7, No. 10, 268.

1 Scope

This British Standard describes a test, the result of which is expressed as pass or fail, which is suitable for pile fabrics and simulated fur fabrics, except floor coverings, and is intended solely for determining whether the pile of these fabrics will promote the rapid spread of flame with which it is in transient contact. The method is applicable to raised fabrics if required and to assemblies having a pile on the surface.

IMPORTANT NOTE. The result of this laboratory test relates to the behaviour of the test specimens as supplied under the particular conditions of test, and does not take into consideration the effects of ageing, washing, soiling, etc. that may be encountered during the life of a product. It has to be recognized that this test cannot give a full assessment of fire properties in all situations, for instance a pass result does not guarantee freedom from surface flash after heating e.g. by exposure to radiant heat.

NOTE The titles of the publications referred to in this standard are listed on the inside back cover.

2 Definition

For the purposes of this British Standard the following definition applies.

surface flash

rapid spread of flame over the surface of a material without ignition of its basic structure

NOTE However, if ignition of the basic structure occurs simultaneously or sequentially with surface flash, it is not considered as part of surface flash.

3 Principle

A sheet of fabric is held vertically in a substantially draught-free enclosure and a flame is moved across the surface of the pile at a known speed to determine whether flame from the igniting source flashes over the surface of the pile.

4 Apparatus

4.1 Non-combustible backplate, at least 400 mm by 130 mm with two horizontal bars for clamping the specimen to it in such a way that the top edge of the specimen is level with the top edge of the backplate. In the vertical plane the backplate shall be fixed parallel to the guide rails of the burner. A means shall be provided for adjusting the position of the backplate in the direction of its normal axis (see Figure 1), so that the pile surface of the specimen is 5 mm from the end of the burner tube when the latter is in the horizontal position.

4.2 Horizontal tube burner³⁾, of 3 mm bore with the dimensions as shown in Figure 2.

The burner shall be mounted on guide rails or pivots so that it can move in a horizontal line parallel to the backplate, in such a way, that, when the igniting flame approaches and is applied to the specimen, the axis of the burner tube is substantially normal to the plane of the specimen, and is directed to a point 15 mm above the upper edge of the lower horizontal bar. For adjustment of the size of the flame, the burner tube shall be capable of being held with its axis vertical.

4.3 Supply of commercial butane, complying with BS 4250.

4.4 Means for moving the burner horizontally across the fabric, at a linear speed of approximately 150 mm per second with the end of the burner tube 5 mm from the surface of the fabric pile. Figure 1 depicts suitable apparatus in which the burner is caused to traverse in front of the specimen by a cord attached to a piston falling in a vertical cylinder. The cylinder is open at the bottom but closed at the top except for a small variable aperture; the rate of descent of the piston is adjusted by varying the size of the aperture. Alternatively, a motor drive may be used.

4.5 Means for providing the atmospheres, for conditioning and for testing the specimens.

5 Conditioning and testing atmospheres

5.1 Conditioning atmosphere. Specimens shall be conditioned in the standard atmosphere for testing textiles as defined in BS 1051, i.e. a temperature of 20 ± 2 °C and a relative humidity of 65 ± 2 % r.h.

5.2 Testing atmosphere. The test shall be conducted in a substantially draught-free atmosphere having a temperature between 15 °C and 30 °C and a relative humidity between 20 % r.h. and 60 % r.h.

6 Health and safety of operators

There is a risk associated with performing this test and suitable precautions should be taken. The atmosphere of the testing-room, which itself should be of adequate dimensions to avoid endangering the health of operators, should be cleared of smoke and fumes between tests by an extractor fan or other means of ventilation. It should be ensured that the desired atmosphere for testing specified in 5.2 is restored.

³⁾ A burner complying with this standard is available from James H. Heal & Co. Ltd., Richmond Works, Halifax, West Yorkshire, HX3 6EP or from Shirley Institute, Didsbury, Manchester, M20 8RX.

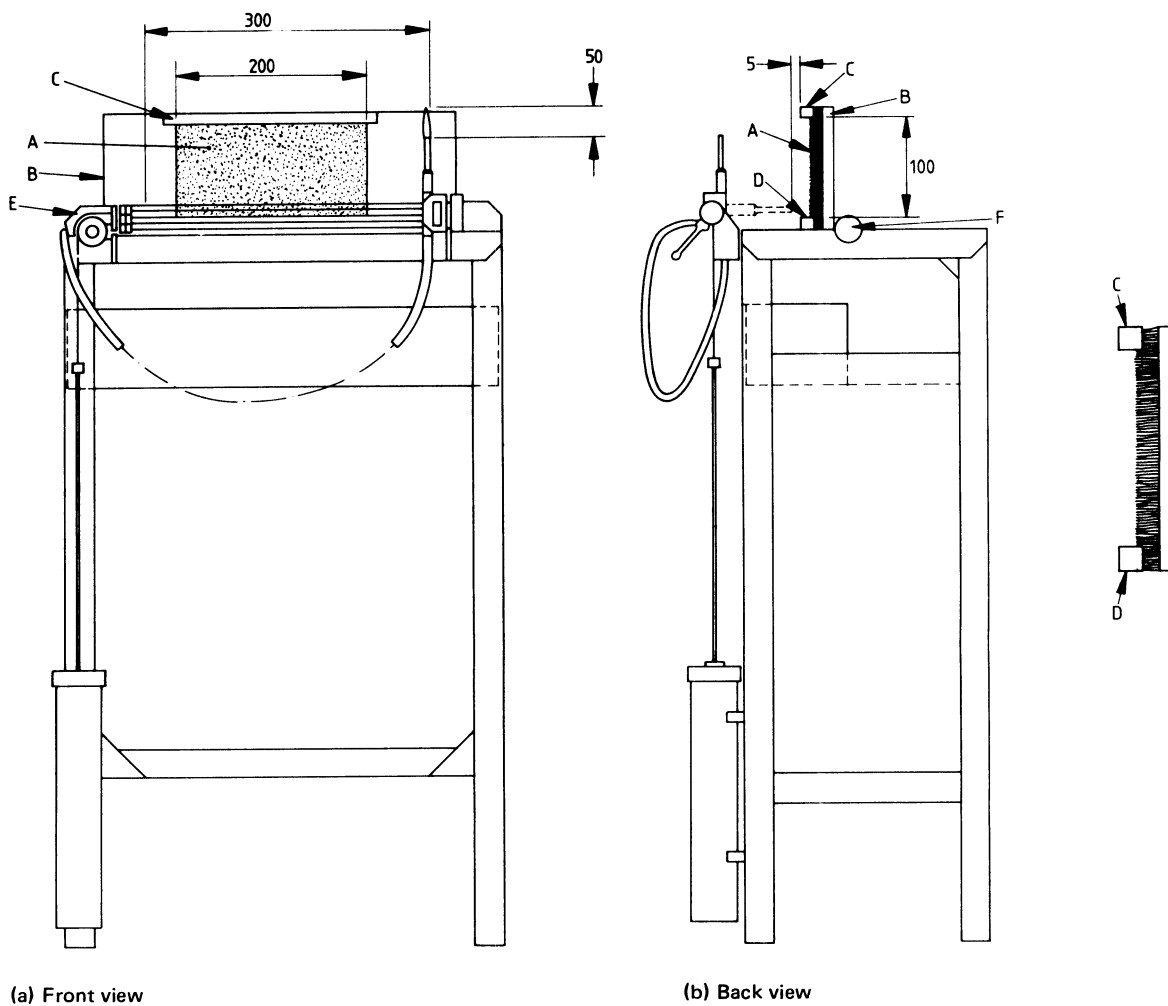

(a) Front view

(b) Back view

- A. Specimen
- B. Non-combustible backplate
- C. Top bar for clamping specimen to backplate
- D. Bottom bar for clamping specimen to backplate
- E. Horizontal guide rails for burner traverse (at least 300 mm between stops)
- F. Ratchet or other means of moving backplate in horizontal plane

All dimensions are in millimetres.

Figure 1 — Apparatus with specimen mounted

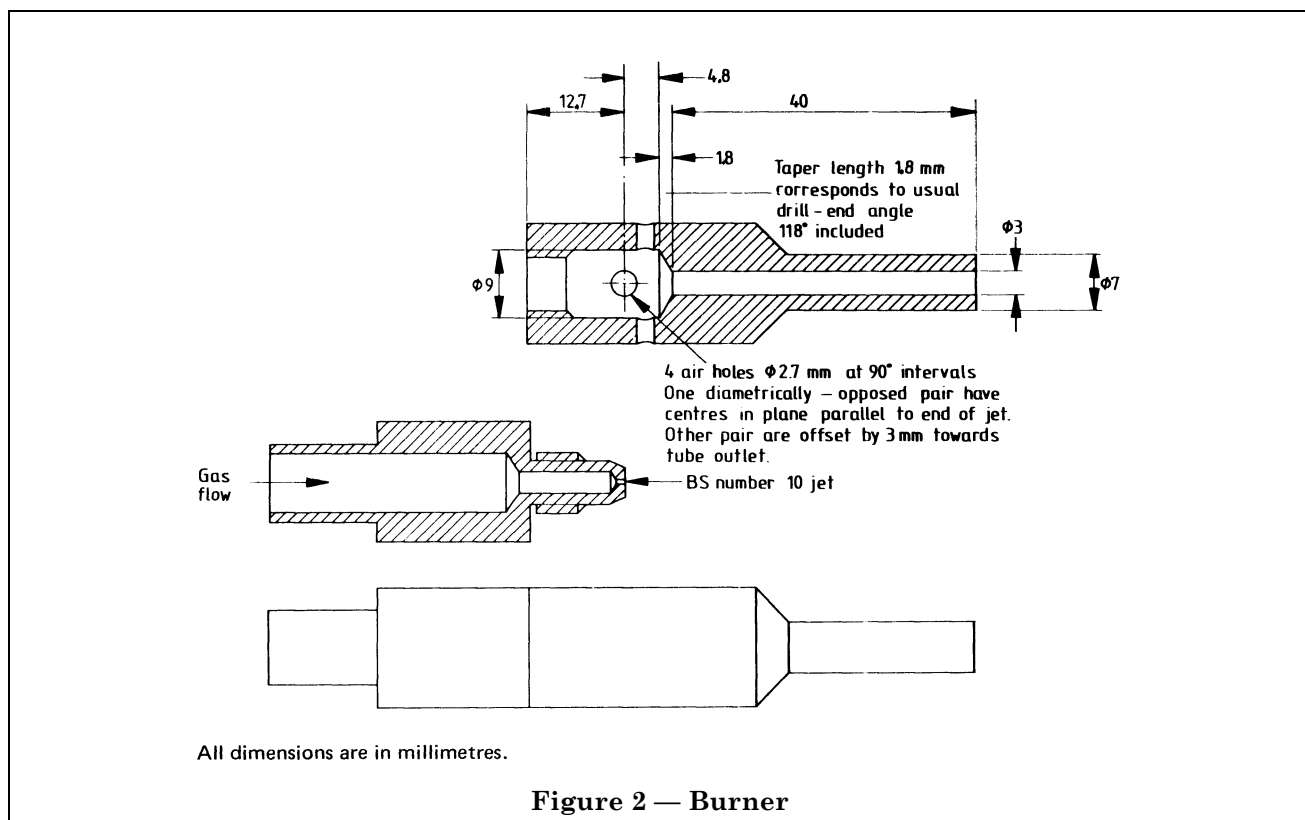

Figure 2 — Burner

7 Test specimens

7.1 Number and dimensions of specimens.

Specimens shall be of either a single fabric or an assembly of two or more superimposed fabrics with pile on the surface. Cut two specimens each 200 mm by 130 mm or larger with the 130 mm sides parallel to the main direction of the lay of the pile. If the pile lay is not apparent, cut two specimens in the machine direction and two specimens in the cross direction and test all four specimens, but report results separately for the two pairs.

If it is necessary to join pieces of the fabric or assembly under test to make up specimens of the required dimensions, e.g. when specimens are being taken from a toy, this should be done by metal staples to join pieces of the same fabric without overlapping.

7.2 Selection of specimens. Select the specimens so that they are as representative as possible of the fabric under test and do not include selvages or areas in which the pile has been damaged.

7.3 Conditioning of specimens. If required, subject the specimens to an appropriate cleansing procedure from those described in BS 5651 before testing. Condition the specimens from the dry side for not less than 4 h in the standard atmosphere for conditioning textiles. Test each specimen within 2 min of its removal from the conditioning atmosphere.

8 Procedure

8.1 Mounting of specimens. Raise the pile of the fabric by shaking the specimen when held by the edge to which the pile is pointing. If the pile lay is not apparent and four specimens are therefore being tested, hold each specimen by one of its longer edges and shake it.

Clamp the specimen along its longer edges to the backplate so that the pile is pointing predominantly downwards, ensuring that the top edge of the specimen is level with the top edge of the backplate and that the specimen is flat against the backplate. Adjust the location of the backplate so that the surface of the pile will be 5 mm from the end of the burner when in its traversing position.

8.2 Control of flame height. With the burner vertical, adjust it to give a flame 50 mm long, measured from the end of the burner tube to the top of the visible flame.

8.3 Flame application. Place the burner in the horizontal position and by means of the traversing mechanism move the burner from 50 mm beyond one side of the test specimen to 50 mm beyond the other in 2 ± 0.2 s at constant speed.

8.4 Observation. Record whether surface flash of the pile fabric occurs, i.e. whether ignition of the surface of the pile occurs substantially over the total area of the specimen within the total traverse time of the flame. If any damage is caused to the ground fabric, note and report this.

If surface flash does not occur on the first specimen, repeat the test on the second specimen.

9 Assessment

If no surface flash, as described in **8.3**, occurs on either specimen, the fabric is regarded as having passed the test. If surface flash occurs on either specimen the fabric is regarded as having failed the test.

10 Test report

The test report shall state the following:

- a) a reference to this standard;
- b) whether the fabric passed or failed the test;
- c) the number of specimens tested and whether they were made up from small pieces;
- d) whether the specimens were tested as received or after a cleansing procedure from BS 5651, and if so, a reference to the particular procedure employed;
- e) details of any deviation from the specified test procedure.

Publications referred to

BS 1051, *Glossary of terms relating to the conditioning, testing and mass determination of textiles.*

BS 4250, *Commercial butane and propane.*

BS 5438, *Methods of test for flammability of vertically oriented textile fabrics and fabric assemblies subjected to a small igniting flame⁴⁾.*

BS 5651, *Cleansing and wetting procedures for use in the assessment of the effect of cleansing and wetting on the flammability of textile fabrics and fabric assemblies.*

⁴⁾ Referred to in the foreword only.

BSI — British Standards Institution

BSI is the independent national body responsible for preparing British Standards. It presents the UK view on standards in Europe and at the international level. It is incorporated by Royal Charter.

Revisions

British Standards are updated by amendment or revision. Users of British Standards should make sure that they possess the latest amendments or editions.

It is the constant aim of BSI to improve the quality of our products and services. We would be grateful if anyone finding an inaccuracy or ambiguity while using this British Standard would inform the Secretary of the technical committee responsible, the identity of which can be found on the inside front cover. Tel: 020 8996 9000. Fax: 020 8996 7400.

BSI offers members an individual updating service called PLUS which ensures that subscribers automatically receive the latest editions of standards.

Buying standards

Orders for all BSI, international and foreign standards publications should be addressed to Customer Services. Tel: 020 8996 9001. Fax: 020 8996 7001.

In response to orders for international standards, it is BSI policy to supply the BSI implementation of those that have been published as British Standards, unless otherwise requested.

Information on standards

BSI provides a wide range of information on national, European and international standards through its Library and its Technical Help to Exporters Service. Various BSI electronic information services are also available which give details on all its products and services. Contact the Information Centre. Tel: 020 8996 7111. Fax: 020 8996 7048.

Subscribing members of BSI are kept up to date with standards developments and receive substantial discounts on the purchase price of standards. For details of these and other benefits contact Membership Administration. Tel: 020 8996 7002. Fax: 020 8996 7001.

Copyright

Copyright subsists in all BSI publications. BSI also holds the copyright, in the UK, of the publications of the international standardization bodies. Except as permitted under the Copyright, Designs and Patents Act 1988 no extract may be reproduced, stored in a retrieval system or transmitted in any form or by any means – electronic, photocopying, recording or otherwise – without prior written permission from BSI.

This does not preclude the free use, in the course of implementing the standard, of necessary details such as symbols, and size, type or grade designations. If these details are to be used for any other purpose than implementation then the prior written permission of BSI must be obtained.

If permission is granted, the terms may include royalty payments or a licensing agreement. Details and advice can be obtained from the Copyright Manager. Tel: 020 8996 7070.